

Projects: 2010

Paul Bourke
Director of iVEC@UWA

Contents: Eye of Nagaur - Virtual heritage
iDome - Place Turkiye
Kinect - Exploration as a user interface
Pausiris gallery - Museum of New and Old Art

My world: Displays



960 x 640 pixels



6400 x 5120 pixels

My world: Movies



1920 x 1080 pixels @ 25fps



8192 x 8192 pixels @ 30fps

My world: Images



5600 x 3700 pixels
High end SLR camera



100,000 x 15,000 pixels

EON: Eye of Nagaur



- “Visualizing the inner life of Ahichatragarh Fort and Palace complex at Nagaur, Rajasthan (India). Visitors make an exceptional journey of discovery of Ahichatragarh’s magnificent architectural spaces and the artistic decorations found throughout. Looking through the ‘eye’ of its imposing three-metre diameter circular screen, viewers explore a constellation make an exceptional journey of discovery. Eye of Nagaur a prosthetic eye that reveals the beauty of this fort and palace complex, exploring in fine detail the painted ceilings, floors and wall decorations, hydraulic infrastructure and the unique fusion of Mughal-Rajput architectural features. With almost infinite ‘zoom’ reflecting back the rich life of the former inhabitants.” [ALIVE exhibition, <http://www.cityu.edu.hk/scm/alive/exhibits.htm>]
- Project by Sarah Kenderdine and Jeffrey Shaw, made possible through the vision of His Highness Maharaja Gaj Singh II of Marwar - Jodhpur and The Mehrangarh Museum Trust.
- Realtime exploration of high resolution spherical images, typically 1/3 Gigapixel.
- Implemented in the Unity game engine.

EON: Demonstration

- Two states
 - outside the pearl necklace
 - inside one of the pearls
- Additionally
 - interface help
 - informational screens
 - interface help
- Controls
 - spin the necklace
 - select a pearl
 - pan navigation within the pearl
 - zoom navigation within the pearl
 - exit the pearl
- All navigation can also be performed using regions on the touch panel. Designed for a touch screen installation.



EON: Unity Pro

Challenge: 16 x 300 MPixel images, will not all fit into memory or on the graphics card.

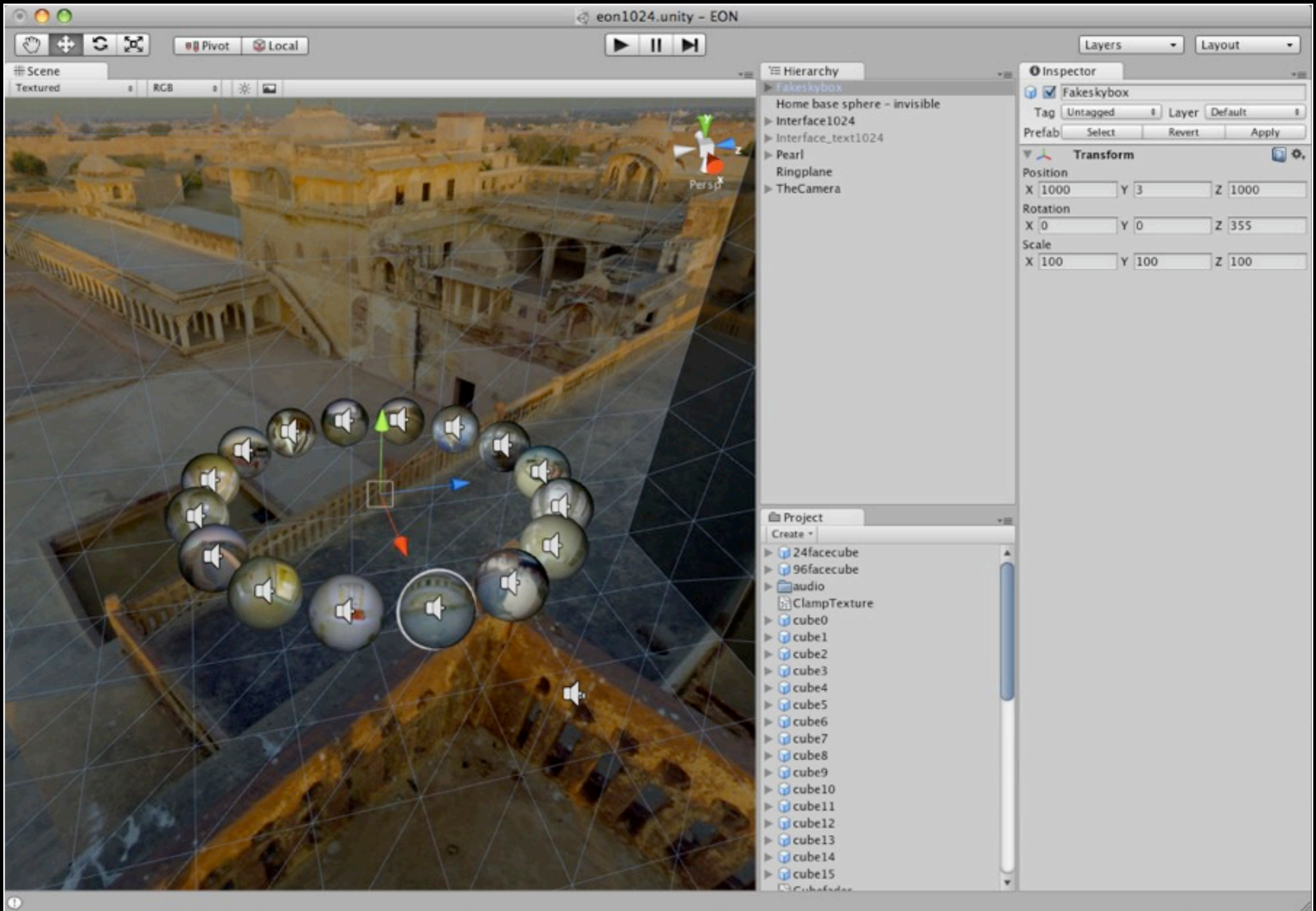

EON: Unity

Performance achieved with tiled textures, visible texture tiles are dynamically loaded from disk.

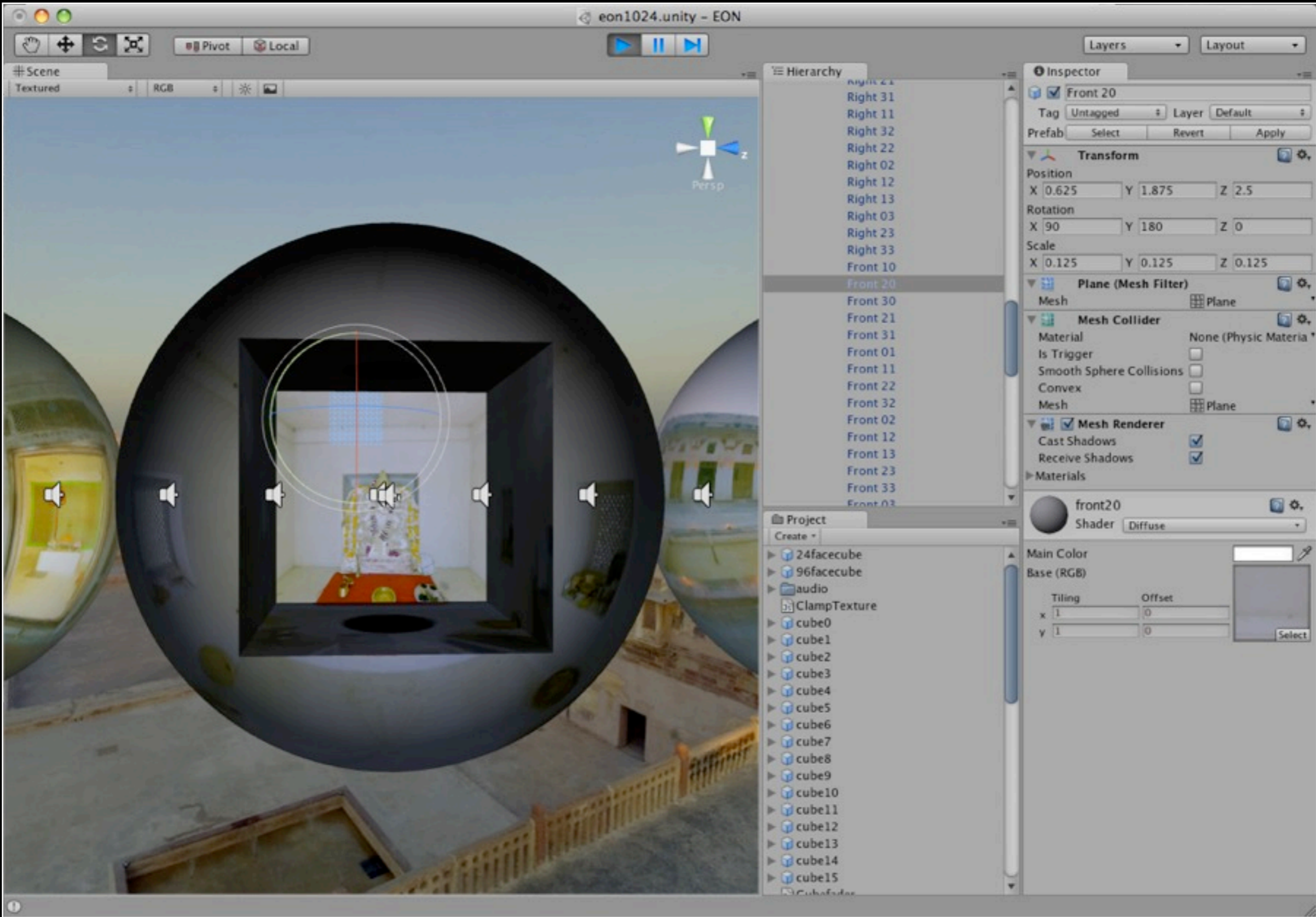

EON: iPhone version

- Navigation in the iPhone version only uses the invisible touch zones.
- Image resolution limited to 2K textures.



iDome: Place Turkiye

- Personal immersive environment, 3m diameter.
- 180 degrees horizontally by 135 degrees vertically.
- Designed for exploring 180 degree fisheye or 360 degree spherical images or video.
- Uses a single HD projector and spherical mirror as the projection system.

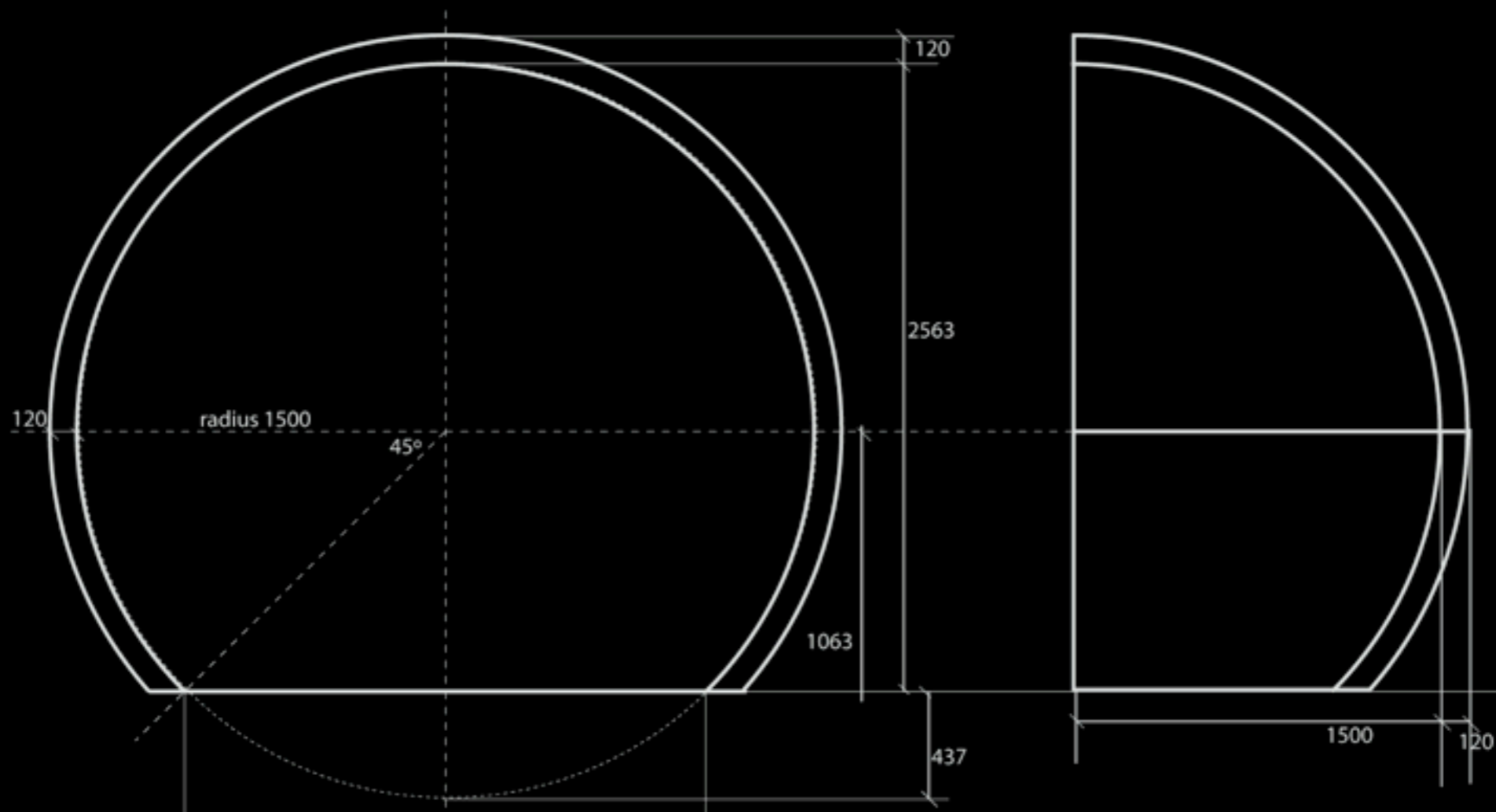

LadyBug Camera

- Captures video across 360 degrees of longitude and 150 degrees of latitude.
- Stitch of 6 separate cameras, results in 5400x2700 pixel movies.
- Large data rate $\sim 60\text{MB/sec} = 3.6\text{GB/min}$.

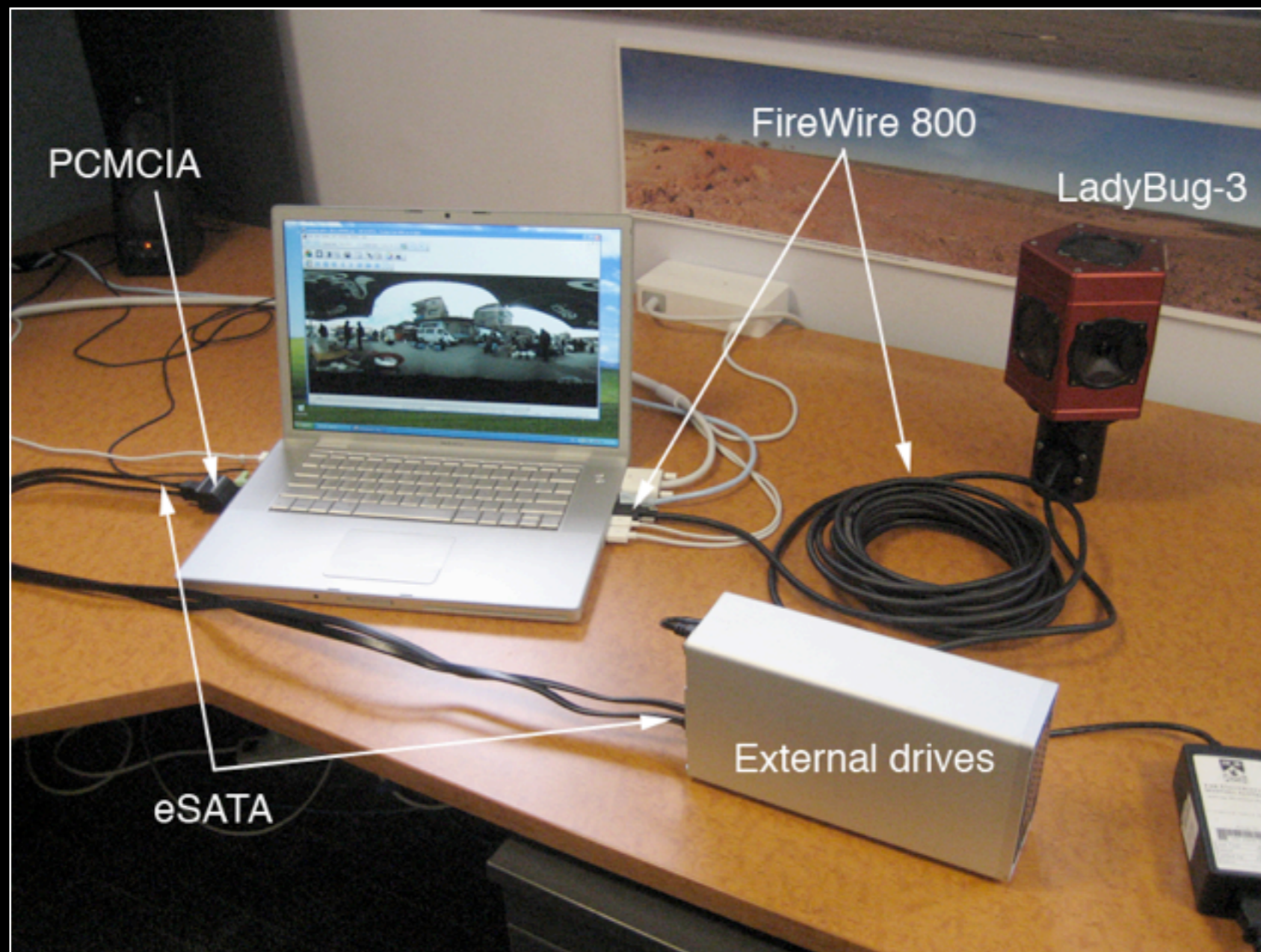

Whirling dervishes: Orient Express Train Station



Semazenler (Istanbul Sirkeci Train Station)
Mevlâna Semazenler (The Whirling Dervishes)

Captured footage

- Captured a number of Turkish cultural events.
- Many are increasingly touristic or becoming lost because they are only oral traditions.



Whirling dervish, Istanbul

iDome: Whirling dervish



Hacibektas dancers



Kardeslik Semahi & Aliyar Semahi (Hacibektas Veli Museum)
Bektasi Semahi (Hacibektas Veli Museum performers)

Interactive playback software

- The entire environment is captured, this allows one to explore while the movie is playing ... same idea as QuickTime VR but a movie rather than a static photograph.
- Spherical projection images need to be warped in order to drive the iDome.
- Patch was written for Quartz Composer (pbmesh) that performs the warping in realtime. Capable to warping a 4Kx2K spherical image @ 30fps.

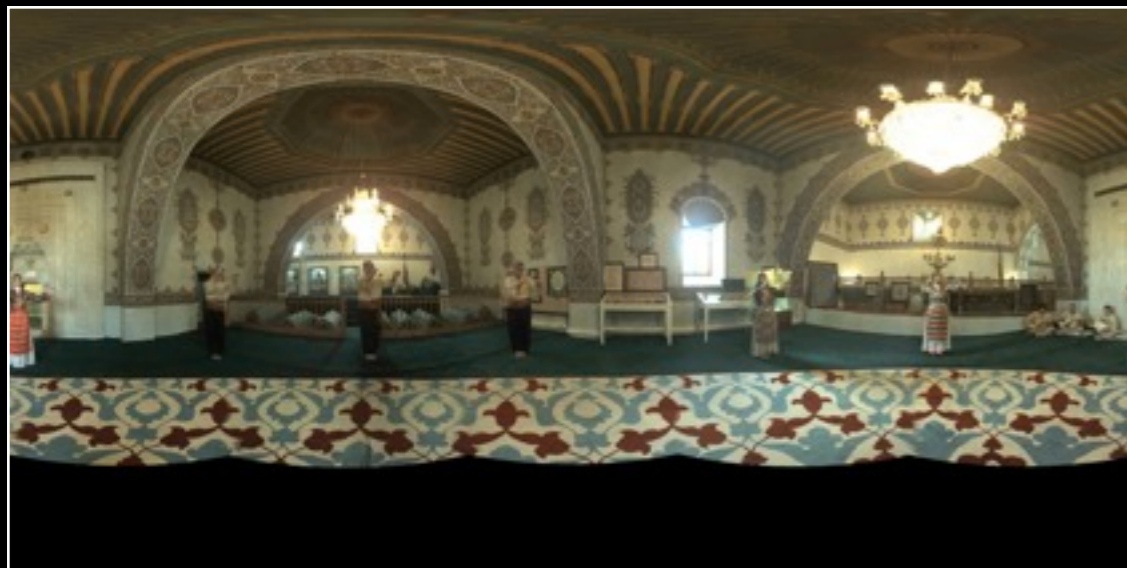

Spherical projection
Output movie frames
from Ladybug camera

Realtime
movie warping



Fisheye image
For use with projector
with a fisheye lens.



Warped fisheye.
For the iDome with
a spherical mirror.

iDome: Hacibektas

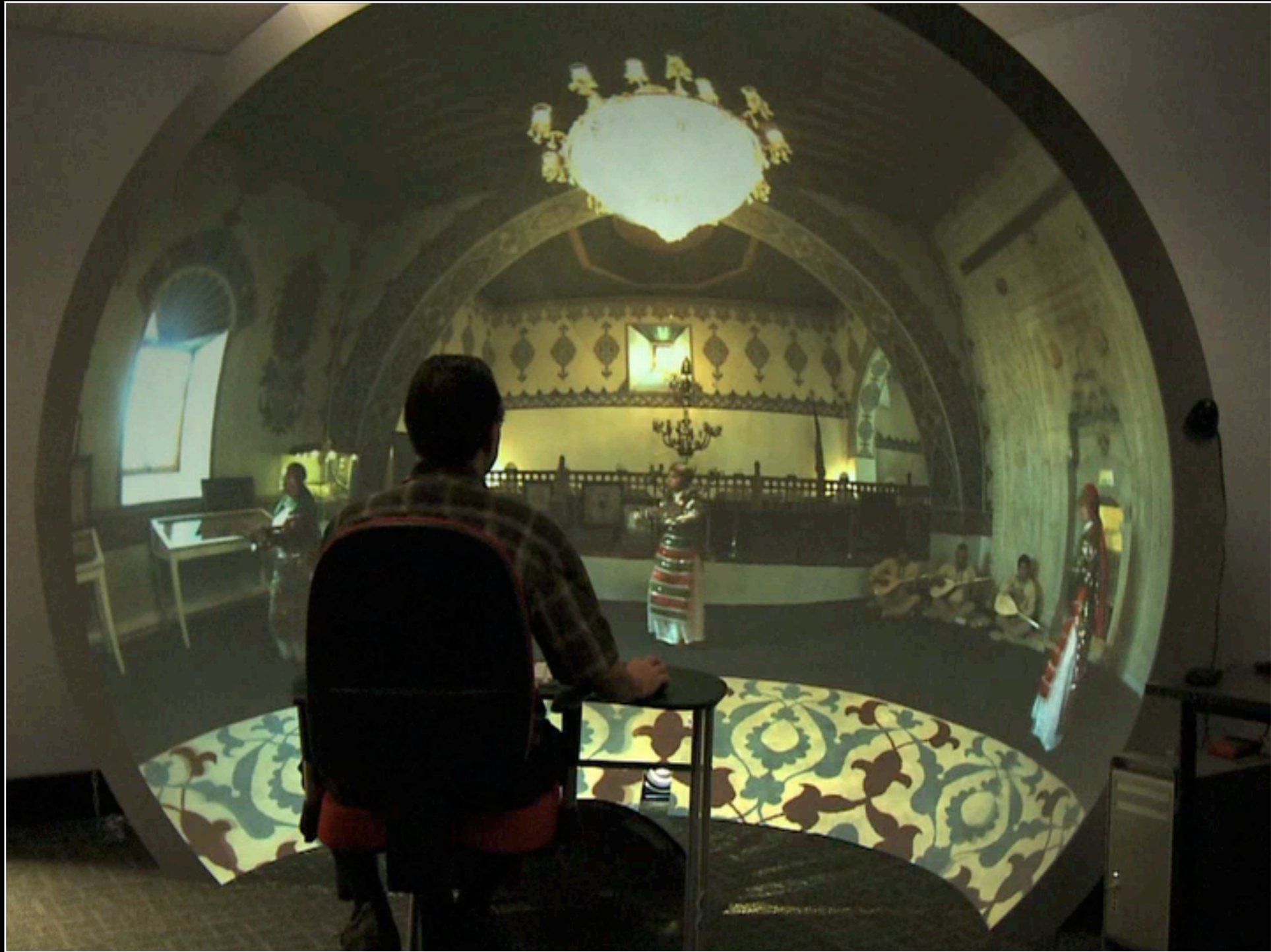

National Orchestra



Feeding pigeons in front of the Yeni Mosque



Kinect: Camera based tracking for user interfaces

- Original device by Primesense, licensed by MicroSoft for the Xbox.
- Various attempts were made to reverse engineering the Kinect as soon as it was released.
- \$3000 challenge.
- libfreenet, largely based upon work by Hector Mart was open sourced in November 2010.
- The Primesense drivers and skeletal analysis also now open source.
- One camera gives a standard RGB video stream, the other camera gives derived depth using structured light approach.
- Makes a wide range of camera tracking interfaces significantly easier to implement. No longer need to do the problematic background subtraction.



Primesense

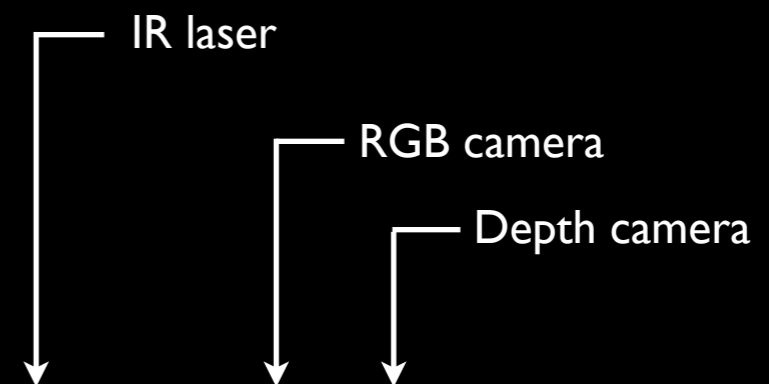

Kinect

Kinect: RGB image and depth image



RGB image
640x480@30fps
1280x1024@15fps

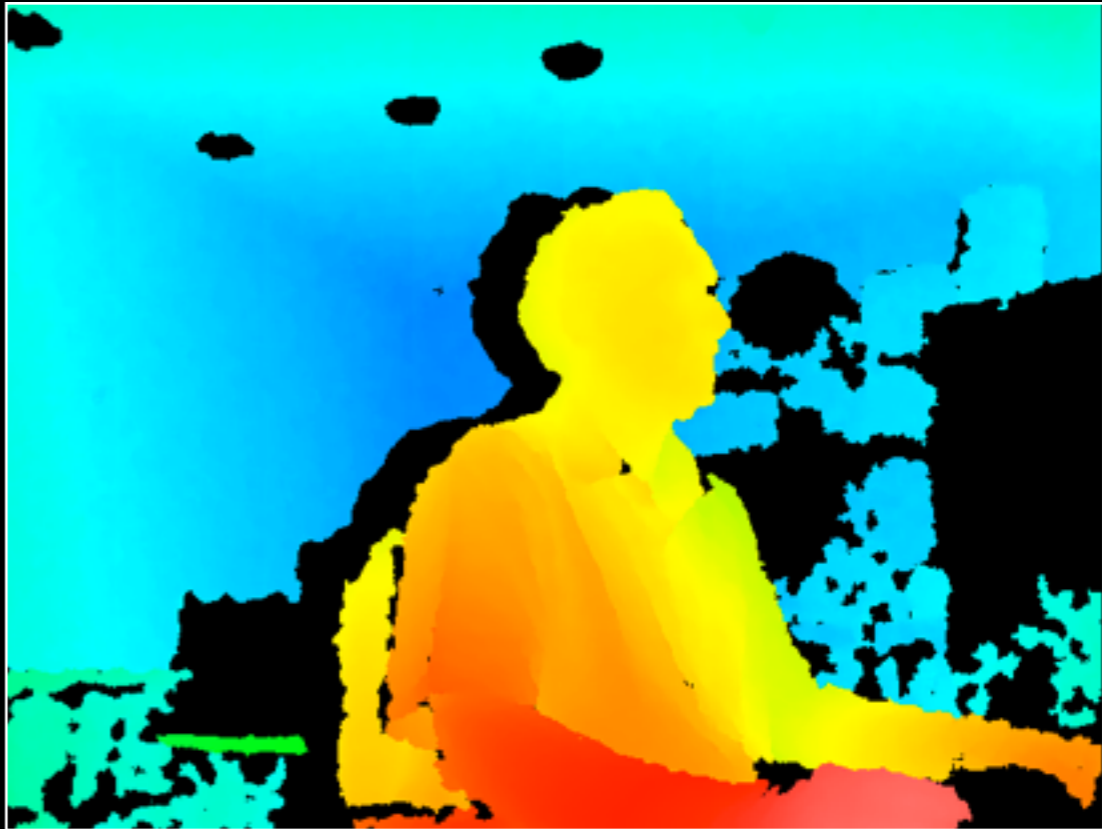

Depth image (colour coded)
11 bit
640x480@30fps



Kinect: Demonstration

- Issues with IR absorbing objects.
- Parallax error between IR emitter and IR camera.
- More sophisticated libraries for skeleton extraction and inverse kinematics.

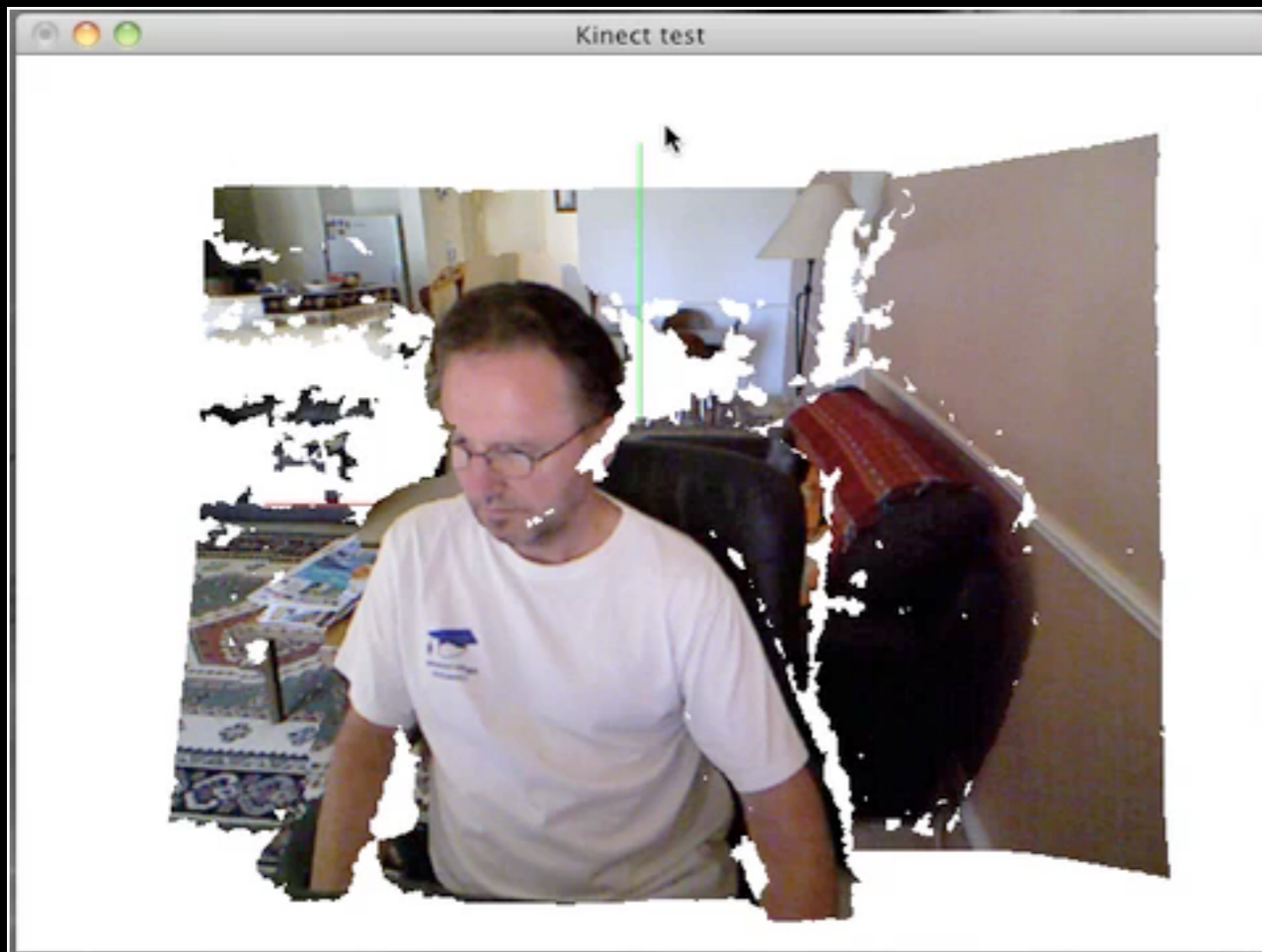

Pointer example

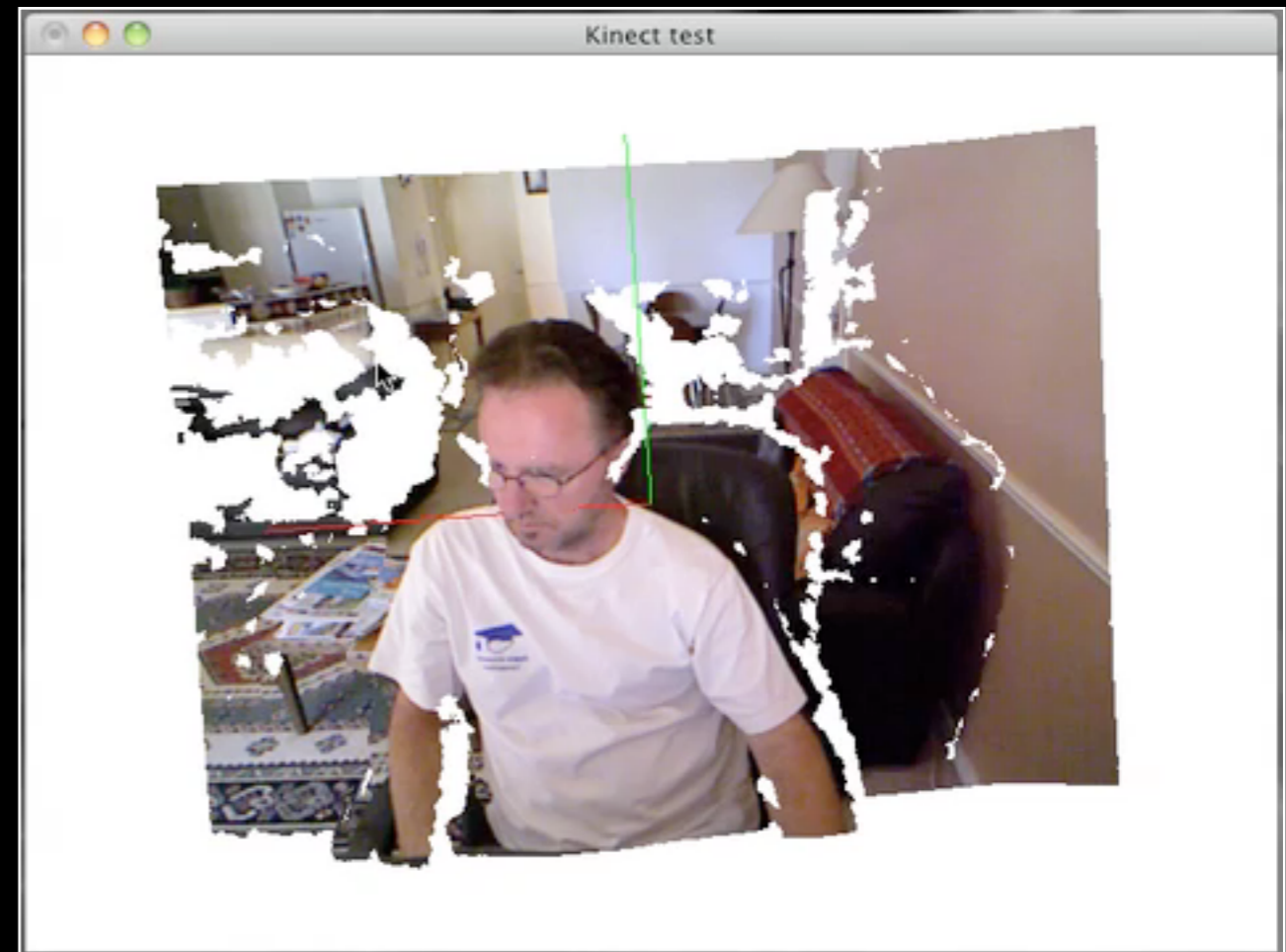

Two hand driving example

MONA: Pausiris exhibition



- MONA: Museum of New and Old Art, Hobart, Tasmania.
- Opened on the 21st January 2011.
- Responsible for an exhibition based upon the Pausiris mummy, in collaboration with Peter Morse.
- Volume rendering from the high resolution CAT scan data using Drishti volume visualisation software. (Developed at the ANU by Ajay Limaye)

MONA: High resolution display

- Each frame of the movie is 4000 x 1500 pixels, runs at 30fps.
- The display case comprises of two 1920 x 1200 pixel projectors.
- Each frame of the movie is split in half (plus an overlap) and sent to each projector. The overlap portion is edge blended to form a seamless 3600 x 1200 pixel image.
- Geometry correction and edge blending need to be performed in realtime due to recalibration if the hardware geometry changes (drifts) and the edge blending adjusted as the projectors age.
- Playback is controlled by network messages: start, stop, pause triggered from laser scanning of the gallery that detects visitors entering and exiting.



Realtime processing pipeline



Movie



Split frame



Apply blending



Apply warping

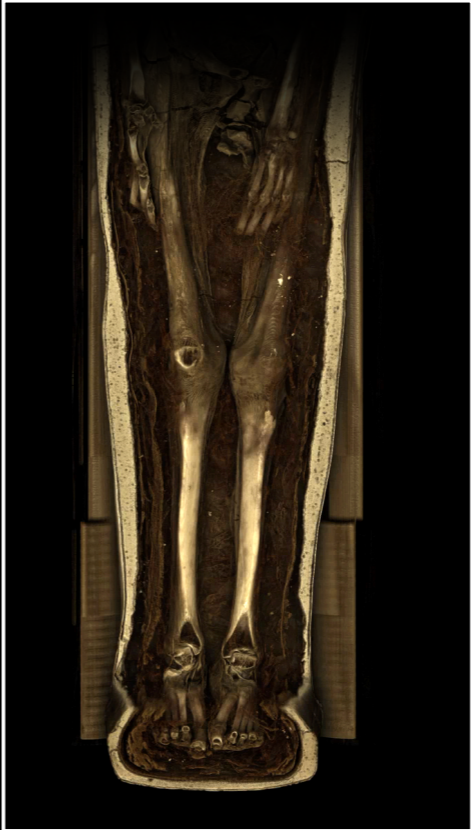
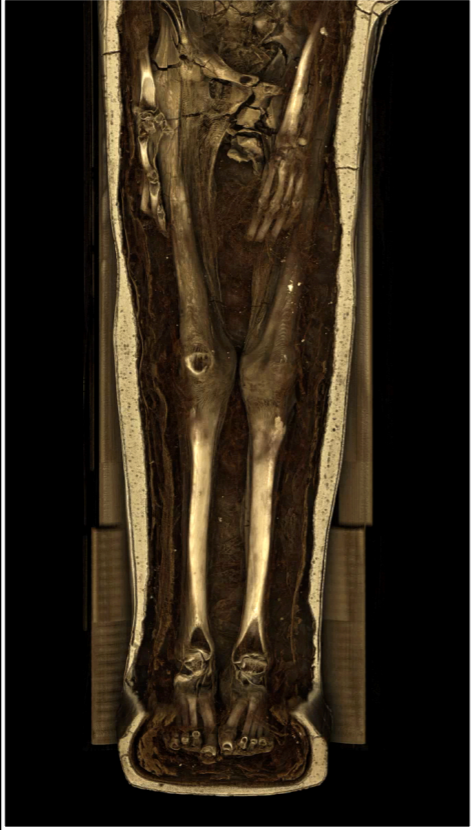

MONA: Quartz Composer playback

- Highly recommend Quartz Composer.
- Designed as a prototyping tool but I invariably end up using it for the final application.
- Excellent source of additional patches at Kineme.net.
- “pbmesh”, my own patch for applying an image/movie to an arbitrary mesh. Image warping control provided by both mesh vertices and texture coordinates.

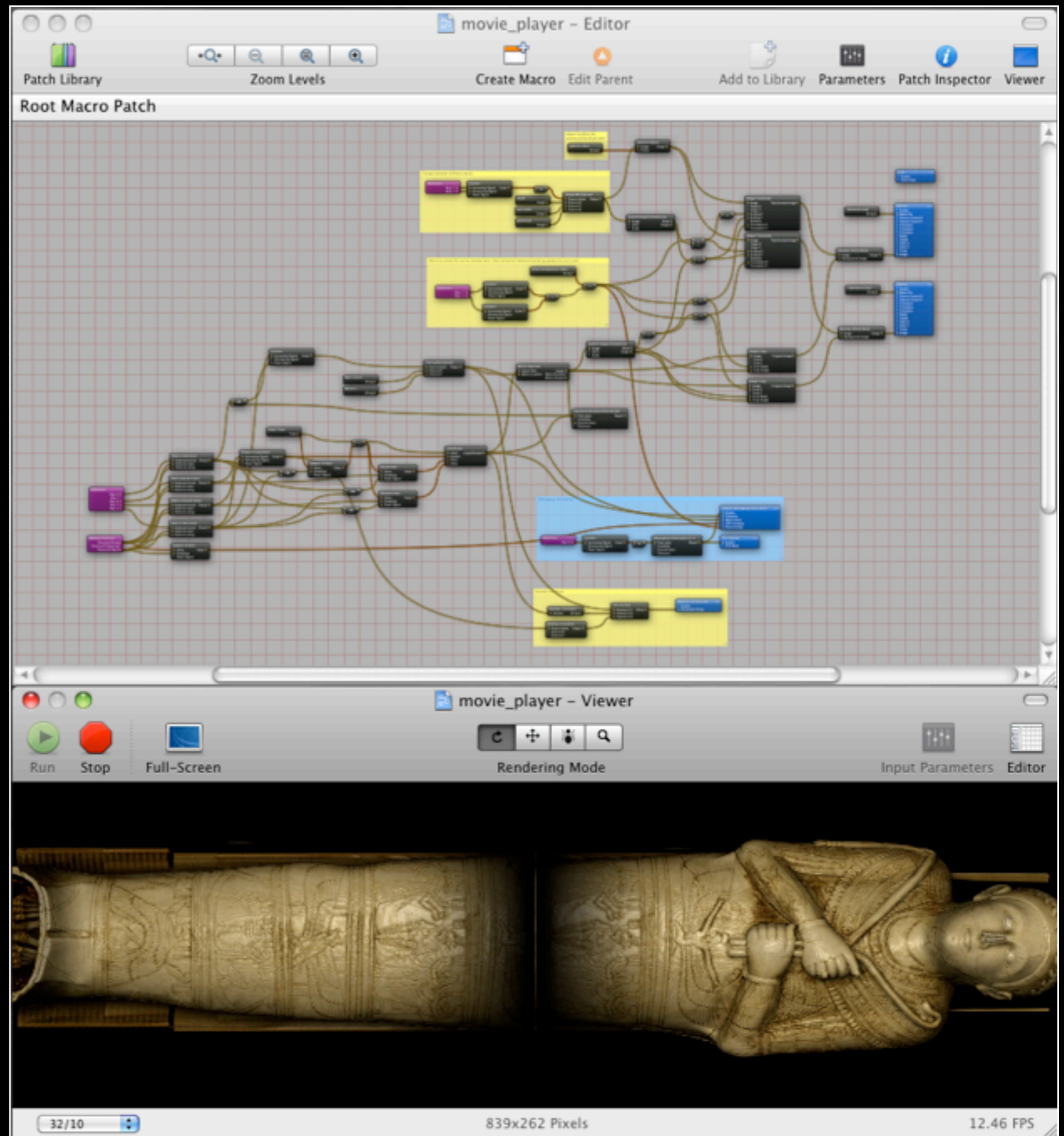

Dual 1920x1200 pixel projector rig





24 hours before the opening



Pausiris gallery



- Room is filled with water containing black dye.
- Only 2-3 people allowed in at one time.

Other galleries: Digestive system

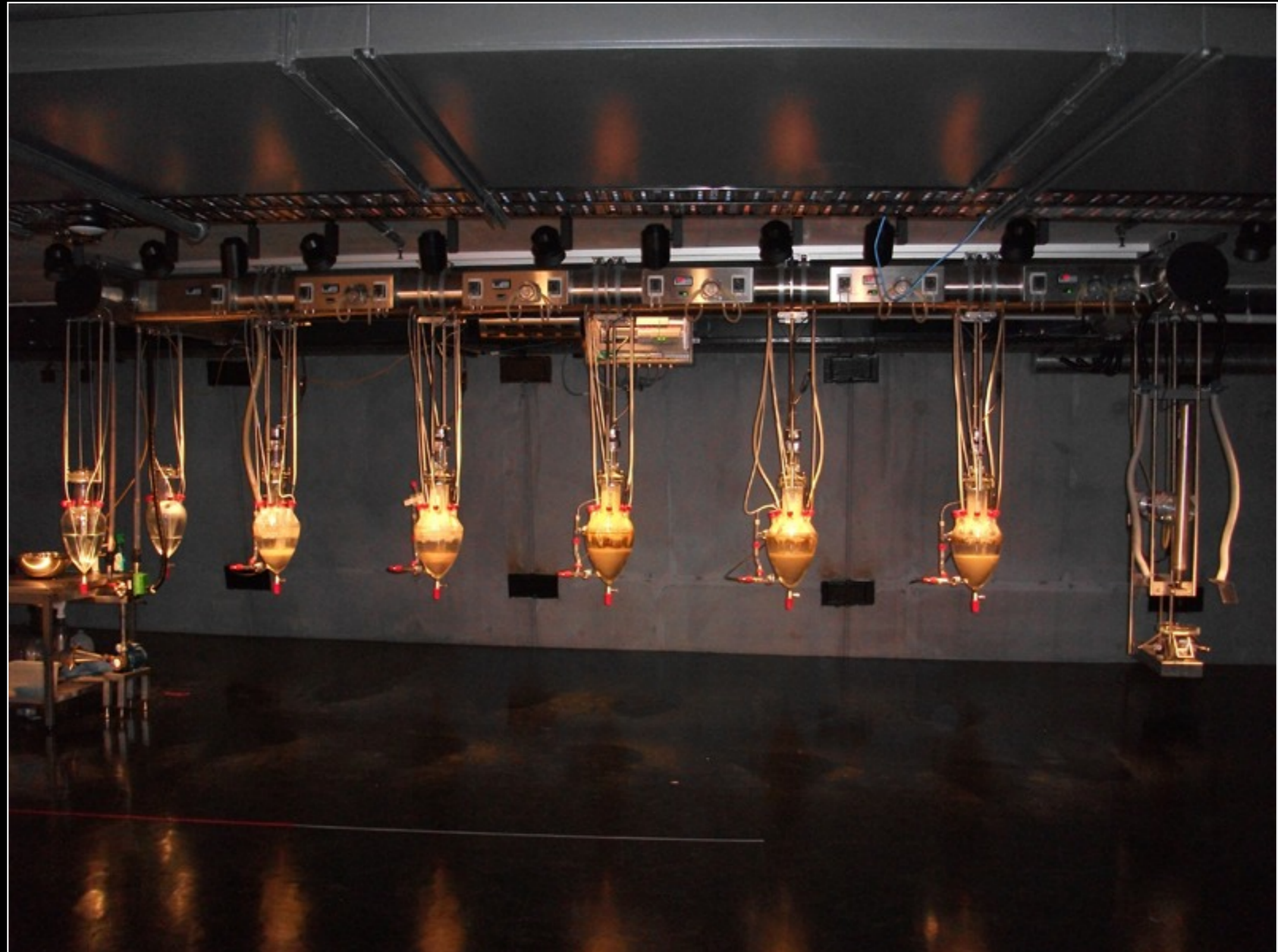

Other galleries: Rotting meat wall

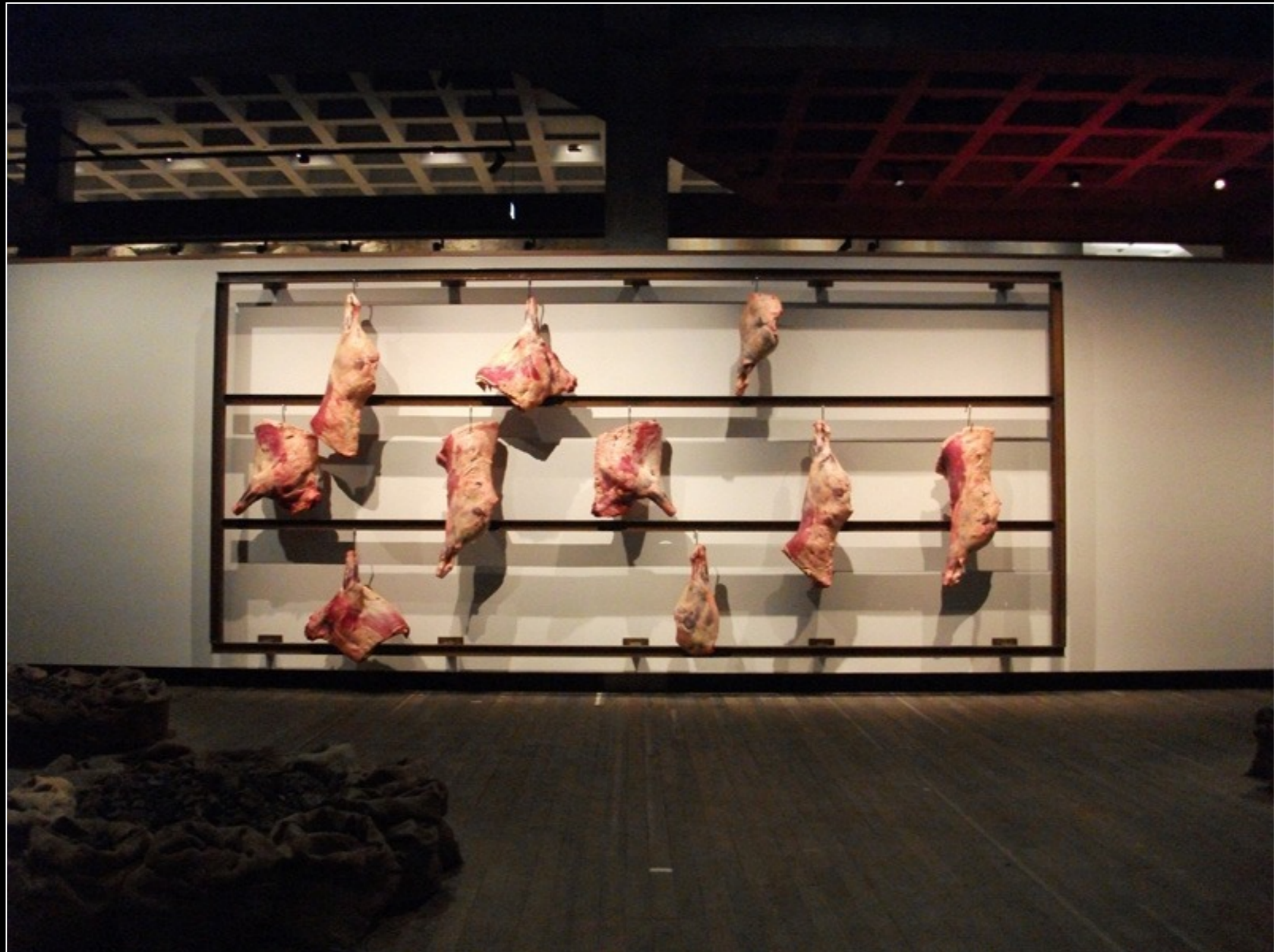

Other galleries: White Library



~1400 iPodTouch units, 280 per charging cabinet



- Location aware iPods, accurate to within a 3m diameter using time of flight to base stations.
- Loaded with information and curatorial comment on each exhibit/gallery, there is no signage in the entire museum.
- Voting system: “love” or “hate”. Can be used as the basis for changing the galleries.



SEATED BABOON

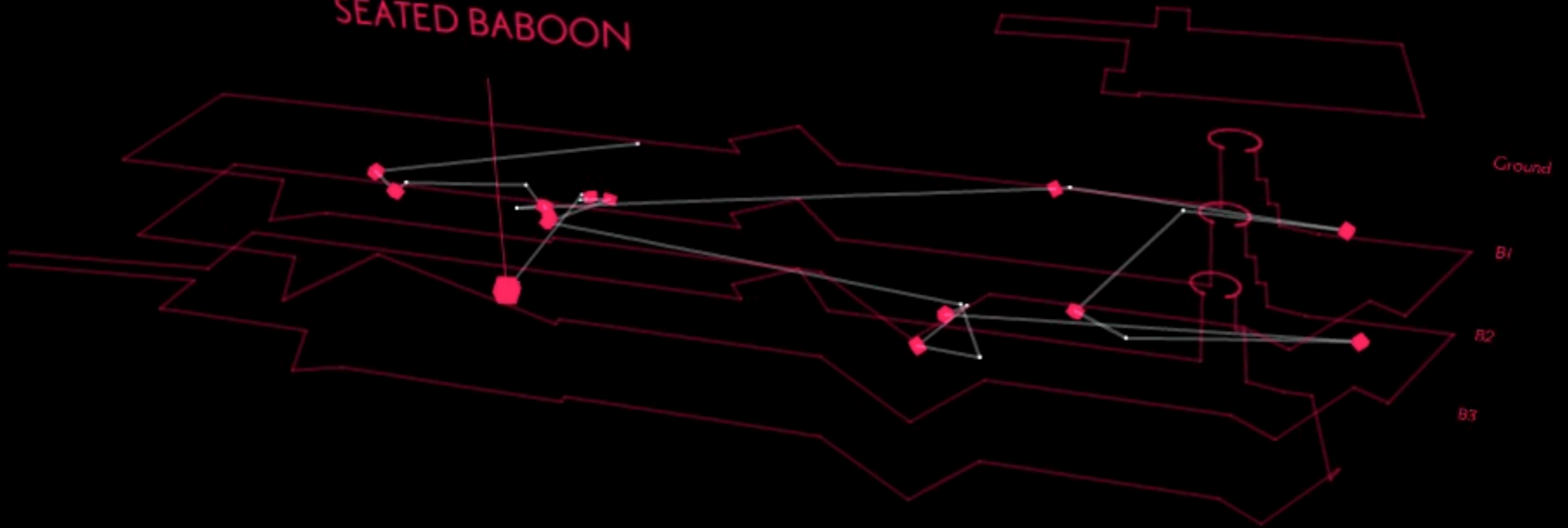

PAUL.BOURKE@GMAIL.COM

Navigate your tour via the 3D model above, or via the artwork listings to the right.

Click and drag your cursor over the 3D model to rotate the perspective. Each pink cube represents an artwork you viewed on The O.

Click on a work to view its interpretive material. This will appear in the far right column.

If you've made more than one visit to Mona use the dropdown menu below to select which visit you wish to view.

VIEWED WORKS

NEIGE ET RENARD HATE
Léopold Rabus

WHEN THE NIGHT FALLS, SECRET LAKES COME OUT (CESARE PACIOTTI) HATE
Amie Dicke

PORTRAIT OF A MAN: WILLIAM WORDSWORTH, 1770-1850, FROM LIFE MASK
Joanna Kane

HEAD OF A MAN LOVE

ECONOMICAL STUDY ON THE SKIN OF

NEIGE ET RENARD LÉOPOLD RABUS



Mixed media on canvas, two panels
Born 1977, Neuchâtel, Switzerland, where he

Questions?